



GUARDIAN
INDUSTRIAL DOORS

GUARDIANDOORS.COM

0800 783 6602

ROLLER SHUTTERS - SECTIONAL OVERHEAD DOORS - INSULATED DOORS - FOLDING DOORS
STEEL DOORS - FIRE RATED DOORS - SECURITY DOORS - SLIDING GATES - HIGH SPEED DOORS

GUARDIAN INDUSTRIAL DOORS

EMERGENCY OPENING PROCEDURES

For emergency callouts and repairs, please call 0800 783 6602

or email support@guardiandoors.com

www.guardiandoors.net



Guardian Industrial Doors Ltd
Managing Director: RW Everitt Company Secretary: E Everitt
Registered Office: 45 Progress Road, Leigh on Sea, Essex SS9 5PR
Fax No 01702 260117
Registered in England No 1447746



GUARDIANDOORS.COM

0800 783 6602

ROLLER SHUTTERS - SECTIONAL OVERHEAD DOORS - INSULATED DOORS - FOLDING DOORS
 STEEL DOORS - FIRE RATED DOORS - SECURITY DOORS - SLIDING GATES - HIGH SPEED DOORS

FOR DOORS WITH HAND CRANK SYSTEMS

The emergency manual operation is provided as a means to open or close the door when power is not available. Manual operation interrupts the control voltage and so electrical operation is no longer possible.



WARNING – Injury risk through improper operation or falling objects

- Disconnect the power supply
- Adopt a secure position
- For drives that have a brake, the brake should be applied before manual operation
- Do not move the door beyond the final limit positions

Insert the crank and turn until it latches (1)

Turn the crank to open or close (2)

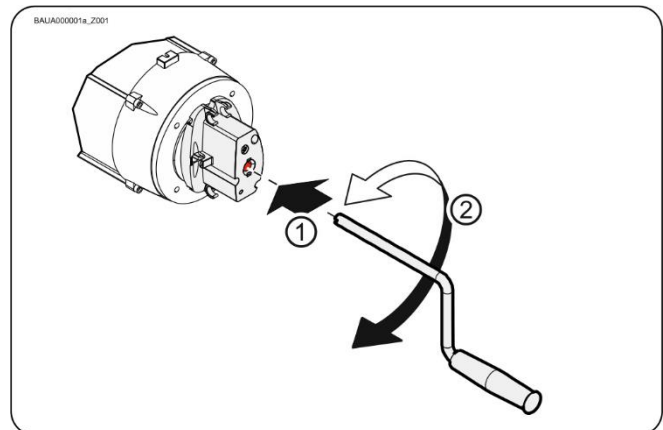

The crank can be mounted to the drive unit after usage

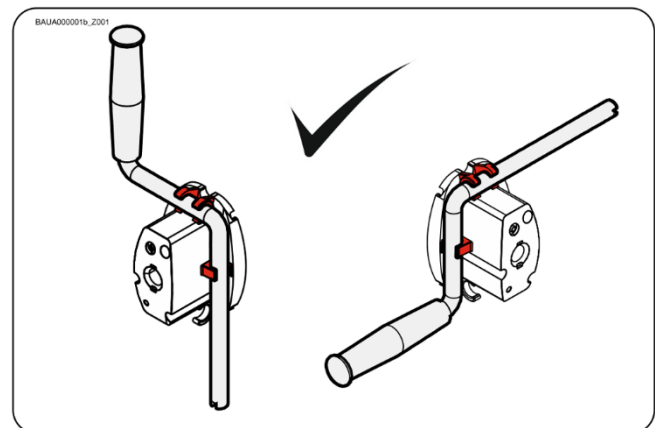

Guardian Industrial Doors Ltd
 Managing Director: RW Everitt Company Secretary: E Everitt
 Registered Office: 45 Progress Road, Leigh on Sea, Essex SS9 5PR
 Fax No 01702 260117
 Registered in England No 1447746



GUARDIANDOORS.COM

0800 783 6602

ROLLER SHUTTERS - SECTIONAL OVERHEAD DOORS - INSULATED DOORS - FOLDING DOORS
STEEL DOORS - FIRE RATED DOORS - SECURITY DOORS - SLIDING GATES - HIGH SPEED DOORS

FOR DOORS WITH HAND CHAIN SYSTEMS

The emergency manual operation is provided as a means to open or close the door when power is not available. Manual operation interrupts the control voltage and so electrical operation is no longer possible.



WARNING – Injury risk through improper operation or falling objects

- Disconnect the power supply
- Adopt a secure position
- For drives that have a brake, the brake should be applied before manual operation
- Do not move the door beyond the final limit positions

Pull the red grip to activate. Pull the chain to open or close. Pull the green grip to deactivate.

